



ABOUT US

Envirolyte IQ is the official and registered trade mark owned by (PTC) one of (Jabal Group) companies as an exclusive distributor for products of Envirolyte Industries International Ltd. in Iraqi territories as an EPC (Engineering, Procurement & Contracting).

Since its establishment, Envirolyte has been a constant follower of world-class technological developments.

In this context, machines that produce disinfectant on-site, which is one of the new developments of the technology world, attracted attention and inspired Envirolyte IQ to focus on this concern.

Envirolyte has set out to make the product economical, highly effective and more useful in every biocidal product produced for human and environment.

Envirolyte constantly renews itself in the biocide field, enriched by scientific knowledge, insight and trust, aimed to meet customer demands with the highest quality and long-term solutions.

Envirolyte will continue its pioneering role in the ecological hygiene world by preserving the understanding of work it has built on the foundations of innovation and sustainability.

ENVIROLYTE DEVICES

On-site disinfectant devices manufactured by Envirolte Industries International for industries where disinfection, water treatment and sterilization are required are brought to Iraq by the company's Iraqi representative, EnvirolteIQ; They offer safe, economical, high efficiency and high hygiene standards to the producer at all stages of production, from health institutions to municipal drinking water, in livestock, greenhouse, from seed to harvest, field to factory, washing to packaging and storage.

Envirolte devices produce a solution with highly antimicrobial effect, called Neutral Anolyte, and is based on the electrochemical activation of water which is known as the electrolysis method.

Machine; Depending on the applied voltage, transfers the brine and the pure water to the electrolysis cell in which anode and cathode poles are separated by a specially designed coaxial membrane and sends positively charged ions to the anode side and negatively charged ions to the cathode side. It transforms water and brine into different new natural compounds with functional properties without adding any other chemical reagents.

With the chemical reaction that occurs, the materials collected on the cathode side are called catholyte (Catholyte), and the substances collected on the anode side are called anolyte (Anolyte).



Anolyte Contains, Hypochlorous Acid - HOCl.

It has a pH range of 2.0 - 8.5 and ORP Voltage of + 700mV to + 1200mV. It is a powerful biocidal product. Anolyte is a clear, colorless liquid and contains "Hypochlorous acid", and is a complex oxidizing substance with high bactericidal, sporicidal, virucidal and fungicidal effect.

Catholyte is a by-product of Anolyte production,

It is an alkaline solution in the pH range of 10.5 -12.5 and is an antioxidant.

It is a degreasing, cleaning and washing liquid that can be used thanks to its sodium hydroxide (NaOH) content.

It is an effective all-purpose cold cleaning detergent that removes biofilm, protein and fat layers on surfaces. Ideal for surface cleaning of walls, floors, appliances and equipment.

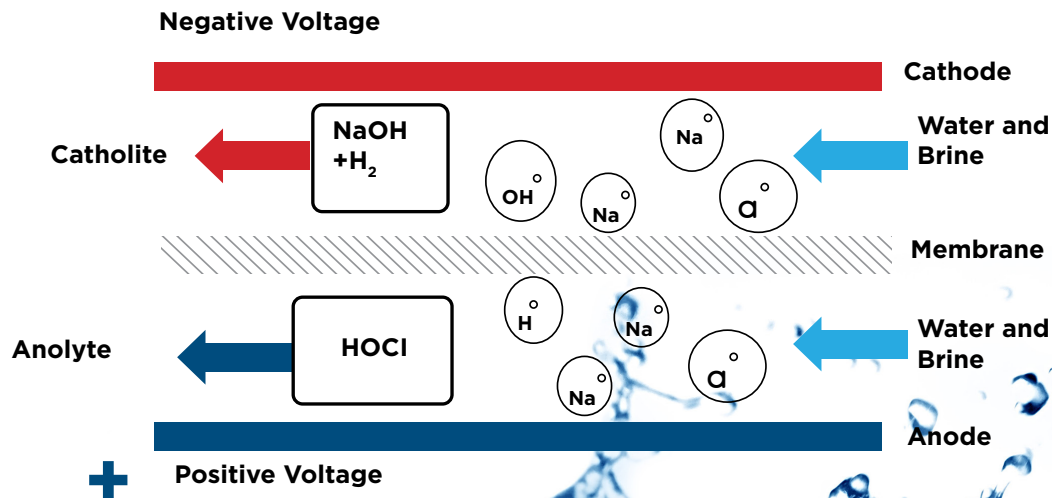

What is Hypochlorous Acid?

When the body is attacked by invaders such as bacteria and viruses, the body's immune system immediately responds by sending an increased number of white blood cells called Neutrophils to the infection site. Once activated, these cells produce significant quantities of the mixed oxidant solution that is highly effective in eliminating all invading microbes and pathogens. The oxidant produced by white blood cells is considered among the strongest natural disinfectants, and it is non-toxic to humans and is highly effective as a fast-acting antimicrobial agent. It is called hypochlorous acid or HOCl.

HOCl is produced under highly specific electrochemical conditions using a combination of water, salt (NaCl) and electricity. Using specially designed and highly controlled production systems, Envirolyte is able to produce stable HOCl at the highest quality and efficiency per liter.

HOCl is extremely effective in eliminating all pathogens and food-spoiling microbes, including spores.



High importance of using ECA solutions

While electrolyzed solutions are largely safe for contact with humans, the same solutions are highly effective at removing bacteria, spores, fungi, viruses and yeasts and molds.

Compared to traditional chemical sanitizations, many microorganisms have been shown to develop tolerance or resistance as a result of continuous exposure to traditional chemicals; however Electrolyzed Water solutions exhibit a unique biocidal action mechanism that is far superior to chemicals. It has been shown over and over again that micro-organisms cannot develop tolerance to ECA technology based on electrical charge.



Hypochlorous (HOCl) is approved by FDA, USDA, ECHA, WHO (World Health Organization) and UNESCO.





Benefits of Electrolyzed Water

- Replacing traditional chemicals with natural ECA solutions can save up to 90% in chemicals costs.
- Electrolyzed water solutions can be recovered and reused several times before being discharged to the drain without adversely affecting the flow and waste outlet.
- Electrolyzed water solutions have been shown to significantly extend the shelf life of fresh products (including meat, fish and value-added products) and can be integrated as an ingredient in sauces / seasonings.
- No shipping or storage costs. Electrolyzed water solutions are installed on site; solutions are stored in tanks available on request.
- Both Anolyte and Catholyte, when used alone or together, have been shown to be effective in removing and controlling biofilm on all liquid contact surfaces.
- Electrolyzed water solutions do not affect the taste, color and appearance of food products.
- It will help ensure compliance with critical micro standards in products that do not contain preservative or pasteurization.
- Wide usage results in significant reduction of toxic waste.
- Electrolyzed water solutions have been shown to be safe for unlimited use by plant personnel as well as application to food and beverage products in all types of production and packaging factories.

Electrolyzed water solutions are green solutions.

ECA solutions eliminate and control all pathogenic organisms including Staphylococcus Aureus and E. coli (O157). ECA specifically reduces the overall microbial bioburden of its spoilage organisms, thus significantly reducing the risk of cross contamination.

Anolyte is used wherever pH is important (corrosion) and where possible evaporation of active chlorine cannot be avoided. It is very effective against bacteria and viruses and is mostly used to disinfect, usage water, purifying drinking water or other water sources.

Neutral Anolyte is also widely used to disinfect / sterilize objects (floors, walls, counter and sinks, equipment, tools, food items, etc.).

Integrate Envirolyte technology into your system to achieve safe, cost-effective cleaning and sanitation compatibility without the use of toxic chemicals.



A typical diagram of Envriolyte Water Disinfection System (EWDS)

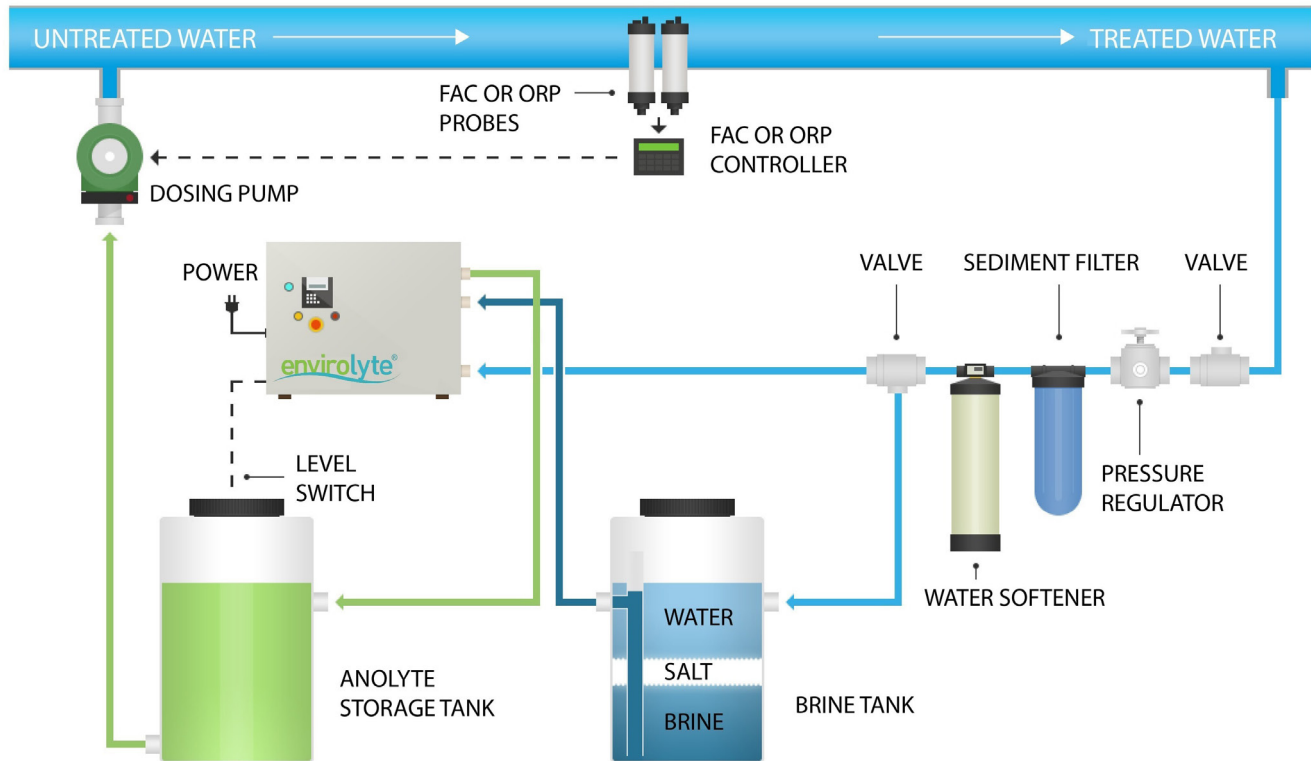

HOW DOES IT WORK?

- Envriolyte water disinfection system consists of:
- Envriolyte Machine (one or more)
- Anolyte and Salt (NaCl) solution vessels.
- Dosing pumps controlled by Free Available Chlorine (FAC) or ORP controller and sensors.
- Anolyte is produced by an Envriolyte unit, stored in a container, and then dosed into the system through a dosing pump and charged into the incoming water source.
- The dosing amount depends on the water flow volume and the quality (properties) of the source water, it can be controlled by a pulsed water flow meter or a FAC / ORP controller and sensor connected to the dosing pump.

How is disinfection achieved?

NaCl (salt water) solution is activated electrochemically within the cell inside the Envirolite machine, producing a powerful, non-toxic, and non-hazardous and non-flammable disinfectant called Anolyte.

Anolyte is a colorless clear liquid with a slight chlorine odor. It contains highly bactericidal, sporicidal, virucidal and fungicidal "Hypochlorous acid" and complex oxidizing agents.



BENEFITS OF ENVIROLYTE SYSTEMS:

- Anolyte diluted in water does not cause any toxic effects nor create any toxic by-products.
- Anolyte penetrates the small pores of water pipes or any other material to disinfect surfaces.
- Anolyte eliminates biofilm and algae.
- Water pipes and equipment do not need to be rinsed with water after any disinfection process.
- Anolyte does not alter the original, natural properties of the water.
- Anolyte eliminates chlorine taste and odor, improves the taste and odor produced by algae.
- Anolyte can be stored for other uses as needed.
- It can be used with simple dosing systems.
- It does not contain any dangerous chemicals.

Comparison of Sodium Hypochlorite and Anolyte

- Although similar in appearance to chlorine, Anolyte is completely unique and clearly superior to sodium hypochlorite in ensuring the destruction of spores, bacteria, viruses and other pathogenic organisms with an equal residue basis.
- Sodium hypochlorite at 5% concentration is only effective for disinfection, not for sterilization, and not against oocysts (Guardia, Cryptosporidium).
- Most waterborne pathogens develop resistance to Sodium hypochlorite over a period of time.
- Since sodium hypochlorite loses strength during prolonged storage, this can also pose a potential danger of gaseous chlorine emissions during storage;

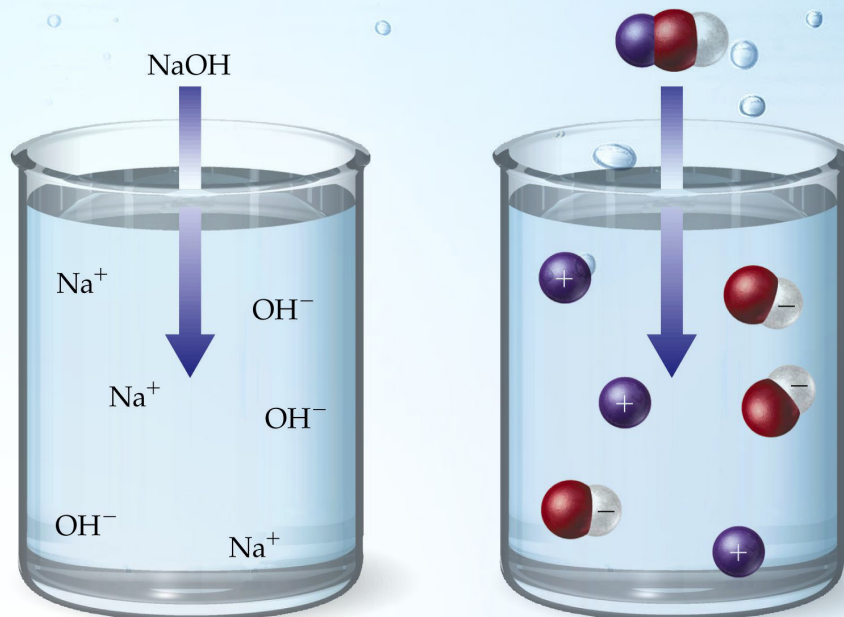

ABOUT LEGIONELLA

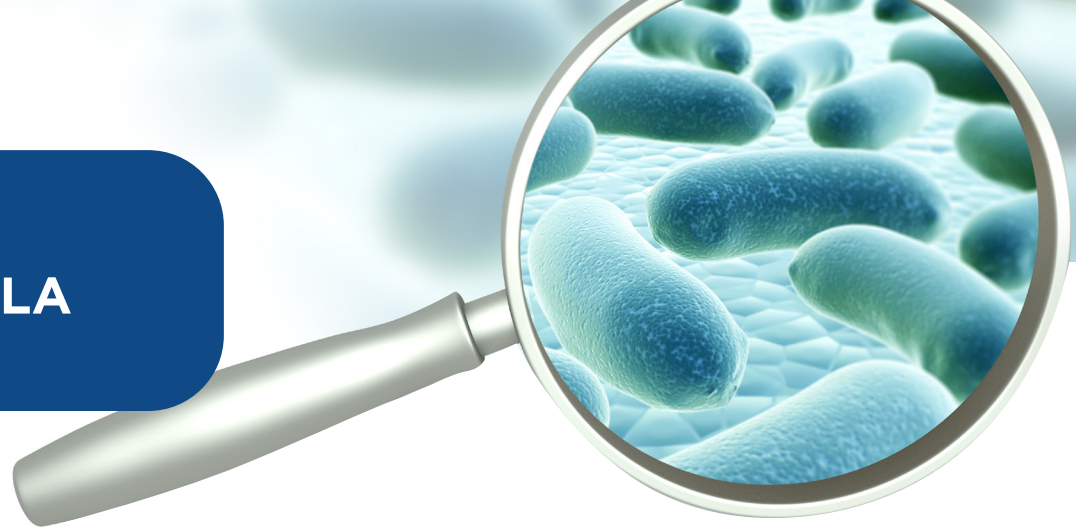

When conventional chlorination work is required because legionella levels are above the recommended limits, all areas of a building where water pipe work and faucet outlets require treatment should be closed for health and safety reasons.

When Anolyte is used as the preferred disinfection method, it is dosed into the water system at low power, usually about 0.25 to 5 ppm, to address Legionella, Pseudomonas, Biofilm or other bacterial issues. Therefore, the treated building, system or areas may remain in use.

The anolyte removes any pathogens hosted in the existing system, as well as blocking dissolved solids in the water, thus eliminating the biofilm during the disinfection process and preventing its regeneration.

It has been scientifically proven that pathogens do not develop resistance against Anolyte's disinfection power for any period of time.

It is completely harmless to both humans and animals at 0.25 to 5 ppm.

WHAT IS BIOFILM LAYER?

- Biofilm layer is a gel-like layer formed by all kinds of organic or inorganic substances and residues on hard surfaces such as dead bacteria. This layer provides shelter and reproduction opportunity to bacteria.
- Legionella, a bacterium that reproduces thanks to the biofilm layer settled in water pipes, is an insidious danger because it cannot be cleaned with known chemicals. Biofilm layer cannot be destroyed by conventional disinfectant or cleaning methods.

Legionella can live and grow in biofilm

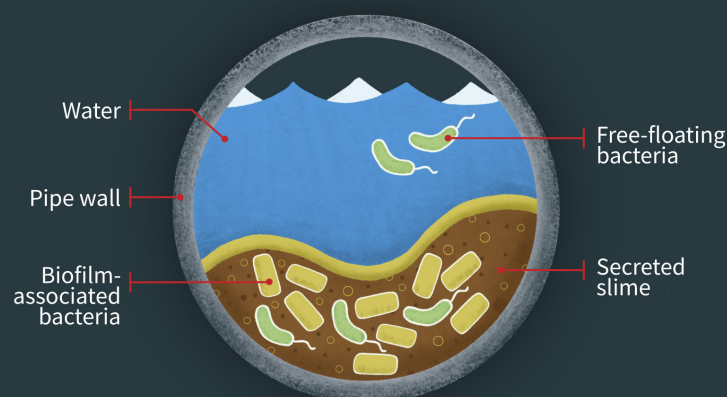

Cross section of pipe

USAGE AREAS OF ENVIROLYTE

Municipalities and Drinking Water Distribution Centers



- Undesirable sediment and stratification in water distribution systems provided by municipalities and drinking water distribution centers, industrial water treatment systems, heat exchangers, water conducting pipes, storage, processing and distribution facilities cause corrosion.
- The biofilm layer formed in the pipelines causes the flow in the pipe to decrease. This layer, which is formed due to organic and inorganic substances adhering to the pipe walls over time in the water system, is like a productive oasis for harmful microorganisms.
- The use of chlorine does not dissolve this substance; bacteria reproduce in the system after the water is disinfected.
- ANOLYTE (HOCl) It is the most effective substance and the most effective biofilm solvent that destroys the biofilm layer formed on the pipe walls that are the cause of epidemics and prevents its re-formation.

Hospitals & Health Institutions

- It eliminates the risk of Legionella decontamination in the water system, which is the biggest risk in hospitals. Especially with the loss of chlorine effect in hot water, it becomes almost impossible to fight Legionella. As HOCl (Hypochlorous Acid) is also effective in hot water, it disinfects 100% of both hot and cold tap water lines, completely eliminating the risk of Legionella.
- It cleans 100% of the biofilm layer (a gel-like layer formed by bacteria) formed in your utility water and waste line without using any chemicals.
- It does not damage your installation because you it is not a highly corrosive chemical.
- You can now produce and use the floor, surface and hand disinfectants used in the hospital yourself, you do not need to buy any disinfectants from outside.
- With the produced disinfectant, materials and equipment used in the "operating room" can be disinfected.
- In hospitals, you can make vegetables and fruits healthy by washing them with a 100% natural disinfectant without the smell of chlorine.
- You can use it in your hospital's heating-cooling systems and cooling towers.
- You do not need to purchase, stock, transport or allocate personnel for any chemical disinfectant such as liquid chlorine, gas chlorine, hydrogen peroxide in your facility.
- While it is necessary to keep the hot water line between 60 - 85 ° C in order to combat Legionella, you can keep the hot water at the desired temperature (around 40-45 ° C) and you can save serious energy.
- You can increase your investment in 2-4 years and then make a very serious profit for your institution.
- As you use an ecological product that is 100% biodegradable, you will not harm the personnel nor the environment.



Educational Institutions

- Disease agents such as bacteria, fungi or parasites are transmitted by air, water and the environment (dust particles).
- Envirolyte is used in Educational institutions to prevent absenteeism caused by infectious diseases, to contribute to the economy by reducing medication and treatment costs; to provide a complete disinfection by removing high carcinogenic cleaners that students are exposed to.



Hotels

- The Hotels are considered as a second home for travellers to stay. It is vital for hotel owners to win their customers' complete trust in their facilities and feel at home. This result can only be achieved by providing good hygiene practices and services. To ensure good sanitization and hygiene
- ECA technology is the best option to use in every step of the way.
- ECA technology would make sure to eliminate bacteria, spores, fungi and microbial cysts in water treatments of hotels for hot and cold water supplies.
- The pools and spas in hotels will have a chlorine-free, microbial-free, and totally safe swimming environment.
- In kitchens and restaurants dish cleaning, food preparation - fruits and vegetables cleaning- general cleaning and surface cleaning can be performed much easier with Envirolyte solutions. Envirolyte products can be used for complete general degreasing and sterilizing all surfaces, appliances and hands. Envirolyte also has food-safe accreditation, and used to improve the shelf life and freshness of products ranging from meats to vegetables and fruit
-
- Housekeeping staff will consume less chemicals and use less variety tools to clean each unit. With Envirolyte solutions maximum performance is achieved with minimum amount of products. General cleaning and disinfection routines such as floors, walls, toilets and bathrooms is easy by using Envirolyte products.
- Envirolyte products can also improve the hygiene in gyms by eliminating odors, disinfect play areas and toys and eliminate moss and fungi growth.





Pools

- Continuously addition of Envirolyte solutions within a swimming pool ensures safe swimming water without the adverse effects of chlorine. Envirolyte solutions destroy all bacteria, virus, fungi and algae at a neutral pH level that is much safer on sensitive skin.
- Since the filter beds can also be sterilized, secondary contamination is also prevented.
- With Envirolyte solutions the chlorine smell, burning eyes and skin irritation are not exists. This is possible to achieve by applying a dilution ratio of 1:1000 liters that guarantees effective decontamination of water.
- The process of producing the solution is much less hazardous to personnel and there are no fumes.
- The labor time for water decontamination will also decrease since operation of the equipment is simple.
- The solution also prevents biofilm layers in the system and there will be no need to disassemble equipment such as injector pumps for cleaning.
- The expenses for water decontamination are three times lower annually in comparison with hypochlorite.

Shopping Malls

- With the dense visitor population, the measures needed to be taken in terms of health increase day by day.
- Thousands of people eating, shopping and chatting at the same time in a closed environment entails different risks.
- The dangers caused by the diseases ranging from seasonal flu to Covid-19 are easily spread around as a result of the breath taken from unhealthy air causing coughing, sneezing, etc. Disinfection is the most important precaution to be taken in cafes, restaurants, playgrounds, toilets, baby nursing rooms, movie theaters, fitness centers and warehouses located in shopping malls.



Livestock Breeding Farms

- It is ideal for creating sterilized living environments for livestock by controlling microbial pathogens, especially in poultry and cattle breeding.
- It can be applied to living areas and dosed into storage tanks to disinfect drinking water.
- Usage areas;
- In the cleaning and disinfection of slaughterhouse operating and utility water, running lines and crates.
- Cleaning and disinfection of product and product preparation areas.
- Cleaning and disinfection of cutting benches, walls, floors, production areas, vehicles, transport crates, tools and equipment.
- In the disinfection of the ambient air by fogging / spraying while the employee is at work.
- In foot baths and hand disinfection units at entries of the production facilities
- Cleaning and disinfection of oily surfaces and crates
- At the end of the season disinfection of the facility walls, floors, feeders and drinkers
- In disinfection of cooling pads and water tanks,
- Disinfection of staff entrance turnstiles hands and aprons
- Hatchery entrance foot bath, surface, floor, wall and hatchery machines disinfection
- Disinfection of used pallets, crates and tools
- Disinfection of indoor ambient air by fogging



Chicken Farms

- Poultry consumes almost twice as much water as feed. During its lifetime, a 2.25 Kg broiler will consume about 8 Litres of water, compared to approximately 4.5 Kg of feed. Water is critical to any animal's health, and bacterial contamination is the primary concern in poultry production.
- Water systems can become contaminated either from groundwater sources or from the environment. Coliform bacteria are easily conveyed to the waters by the birds during their daily activities.
- There are numerous ways to control bacteria. However, fewer has proven to perform effectively and economically. Our Enviolyte (ECA) systems that produce Anolyte contains - Hypochlorous acid (HOCl)- with powerful biocidal effectiveness. The Hypochlorous acid (HOCl) in the system ensures continual disinfection.
- Without Anolyte, pathogens re-contaminate the water systems through the birds in the barn. Anolyte continues to disinfect the systems.
- Even if pathogens are reintroduced to the watering system,
- With Enviolyte systems (ECA) technology implemented to your systems 100% efficacy against all bacteria, viruses, algae and fungi is guaranteed.
- Since Anolyte is also safe for warm blooded animals and humans, implementation to the chicken farms is easy.
- Anolyte keeps the waterlines clean, reduces the ammonia levels, replaces all your disinfection chemicals and reduces the use of medication, since it is an effective and natural disinfectant. It is also environmentally friendly.



Fish Farms & Seafood Products



- Shelf-life validity and spoilage of seafood are serious challenges in the sector. Sea water is often used as a medium for transporting fresh fish. Throughout the transportation procedure, sea water becomes progressively soiled that causes micro-organisms to buildup and result in product spoilage.
- Many aquaculture establishments, most importantly, those with early stages breeding of aquatic animals, require disease prevention and control by applying diversified disinfection methods.
- Disinfection of fish farms is extremely important for all parts including: Eggs and larvae, Materials and equipments, Nets, Vehicles, Staff, Pipelines and tanks, Source water, Effluent water, Large ponds or lakes, Buildings, Clothing and equipments, Crustacean culture systems and equipments.
- Envirolyte ECA solutions eliminate and control all pathogenic organisms, including Staphylococcus Aureus and E.coli (O157). By reducing the overall microbial bio-load of spoilage organisms, it also reduces the risk of cross contamination.
- HOCl is ideally efficient, powerful and natural disinfectant in all these areas. Not only it is environmentally friendly but it is also safe to use on aquatic animals. It improves preservation, promotes growth, increases productivity, reduces mortality and diseases. It also improves quality and eliminates odors.

Food Production Areas

- The freshness of the products will last much longer when you replace the water you will use in washing the products with hypochlorous acid (HOCl) produced on-site, which is safe, natural and effective.
- Complete disinfection is provided without the use of any carcinogenic chemicals or vinegar.
- Since foods washed with hypochlorous (HOCl) do not require rinsing, water savings are also achieved.
- Freshness, appearance quality and shelf life of vegetables, fruits and greens washed with Hypochlorous (HOCl) will increase
- Catholyte easily washes away the pesticides and stubborn chemical film in the flora of fresh vegetables and fruits.
- Envirolyte with Food Safety Accreditation; It is also used to increase the shelf life and freshness of meat, vegetables, fruits and other foods.



Floor & Surfaces Disinfection

- Cleaning surfaces can help in removing pathogens and significantly reduce their load on contaminated surfaces. However, even though cleaning with water, soap and some form of mechanical action removes and reduces dirt, debris and other organic matter, it does not kill microorganisms. Therefore, chemical disinfectants, such as chlorine or alcohol, should be applied after cleaning to kill any remaining microorganisms
- By using EnvirolYTE ECA technology you will need no harsh and toxic chemicals any further to achieve quick and effective disinfection.
- EnvirolYTE solutions are multi-surface disinfectants, sanitizers and deodorizers. They are also environmentally-friendly, non-toxic and non-corrosive, and will effectively eliminate 99.99% of harmful germs and bacteria on hard surfaces with just 60 seconds of wet contact.
- It is safe for use on kitchen equipments and appliances such as dishes, utensils, counter tops, as well as on floors, baths, multi-surfaces etc. Nevertheless, free of harsh fumes, chemical odors or surfaces residues.



Industrial Applications

COOLING SYSTEMS

- Problems associated with cooling systems are scaling and corrosion of pipes caused by biological activity (biofilm and algae growth). Fouling of filling material caused by algae in cooling tower. Frequent emptying of basins from sludge and bioactive material. Poor heat transfer due to biofilm formation - loss of energy / money. Usage of dangerous chemicals in case of algae growth prevention. Generally high operating and maintenance costs. No effective biological activity control
- By using EnvirolYTE solutions biofilm and algae formation is eliminated. Heat transfer is increased and energy loss is minimized. The working time of cooling system is increased with maximum saving in energy.

WASTE WATER

- With increasing pressures on water resources, the concept of beneficial use of treated wastewater has rapidly become vital for water agencies around the world. Water and wastewater recycling and reuse has increasingly been integrated in the planning and development in all countries, particularly for agriculture, irrigation, protection of the public health, increase in water availability, preventing coastal pollution and enhancing water resources and nature conservation policies.
- By using EnvirolYTE ECA systems Anolyte can be generated on-site, in which, results in reducing or recycling waste water. Simultaneously, cost reduction is achieved.
- Significant savings in energy and carbon. Tremendous positive impact on the environment.
- No haloform production which is caused by the exhaustive halogenation.
- It provides safe and ideal results in comparison with other technologies.
- EnvirolYTE Anolyte generators relatively can be introduced as wastewater treatment technologies which can be designed to provide a cost-effective disinfection and environmental protection solutions while providing additional benefits in reusing of water.





P T C

PARU TRADING CO., LTD

Part of **JABALGROUP**

PTC is the official exclusive distributor in Iraq territories for all products made by Enviolyte Industrial International Co., Ltd Estonia EU

BAGHDAD

Al Mansour - Hai Alkendi

ERBIL

Empire Business Towers

☎ : + 964 770 188 8003
T : + 964 750 188 8003
E : info@enviolyteiq.com
W : www.enviolyteiq.com